

Submersible Effluent Pump

MODEL

3871 EP04
EP05

APPLICATIONS

Specifically designed for the following uses:

- Effluent systems
- Homes
- Farms
- Heavy duty sump
- Water transfer
- Dewatering

SPECIFICATIONS

- Solids handling capability: 3/4" maximum.
- Capacities: up to 60 GPM.
- Total heads: up to 31 feet.
- Discharge size: 1 1/2" NPT.
- Mechanical seal: carbon-rotary/ceramic-stationary, BUNA-N elastomers.
- Temperature: 104°F (40°C) continuous, 140°F (60°C) intermittent.
- Fasteners: 300 series stainless steel.
- Capable of running dry without damage to components.

Motor:

- EP04 Single phase: 0.4 HP, 115 or 230 V, 60 Hz, 1550 RPM, built in overload with automatic reset.
- EP05 Single phase: 0.5 HP, 115 V or 230V, 60 Hz, 1550 RPM, built in overload with automatic reset.
- Power cord: 10 foot standard length, 16/3 SJTOW with three prong grounding plug. Optional 20 foot length, 16/3 SJTW with three prong grounding plug (standard on EP05).

- Fully submerged in high grade turbine oil for lubrication and efficient heat transfer.

Available for automatic and manual operation. Automatic models include Mechanical Float Switch assembled and preset at the factory.

FEATURES

- EP04 Impeller: Thermoplastic Semi-open design with pump out vanes for mechanical seal protection.

- EP05 Impeller: Thermoplastic enclosed design for improved performance.

- Casing and Base: Rugged thermoplastic design provides superior strength and corrosion resistance.

- Motor Housing: Cast iron for efficient heat transfer, strength, and durability.

- Motor Cover: Thermoplastic cover with integral handle and float switch attachment points.

- Power Cable: Severe duty rated oil and water resistant.

- Bearings: Upper and lower heavy duty ball bearing construction.

AGENCY LISTING

 Canadian Standards Association
(CSA listed model numbers end in "C" or "F".)

Goolds Pumps is ISO 9001 Registered.

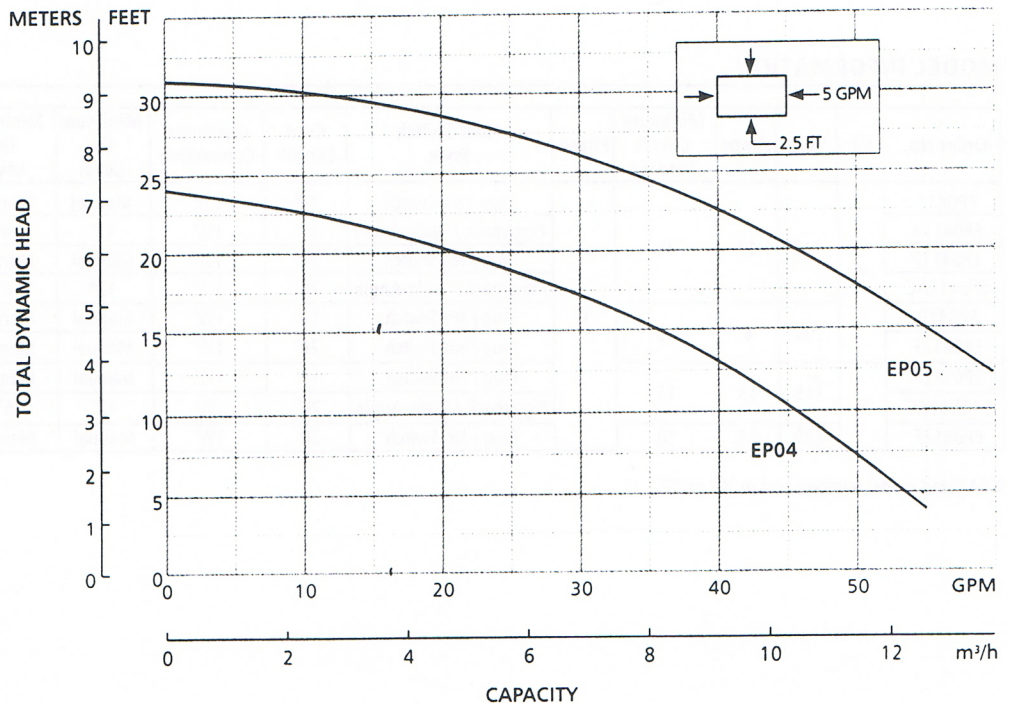

Goolds Pumps



Submersible Effluent Pump

MODEL

3871 EP04
EP05

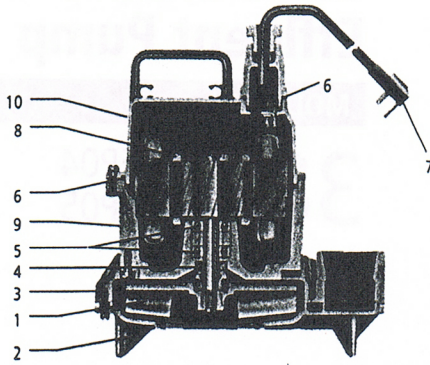

COMPONENTS

| Item No. | Description |
|----------|--|
| 1 | Impeller |
| 2 | Rugged thermoplastic base |
| 3 | Rugged thermoplastic pump casing |
| 4 | Mechanical seal |
| 5 | Ball bearings |
| 6 | O-rings |
| 7 | Power cord |
| 8 | Oil filled motor |
| 9 | Cast iron motor housing/ stator assembly |
| 10 | Thermoplastic motor cover |

DIMENSIONS

(All dimensions are in inches. Do not use for construction purposes.)

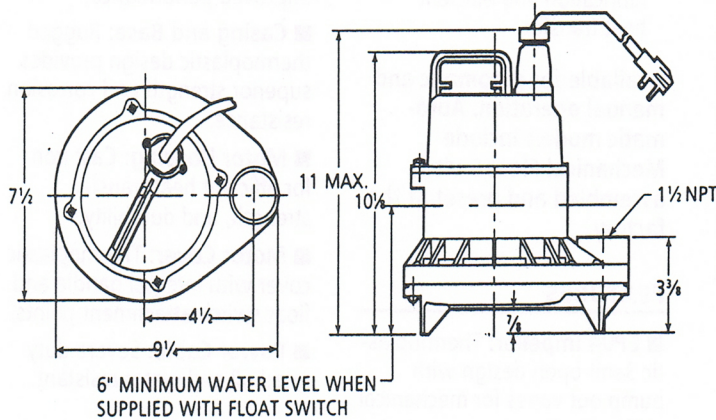

PERFORMANCE RATINGS

| Total Head (ft. of water) | Gallons Per Minute | |
|---------------------------|--------------------|------|
| | EP04 | EP05 |
| 5 | 53 | - |
| 10 | 46 | 62 |
| 15 | 36 | 56 |
| 20 | 21 | 47 |
| 24 | 0 | 38 |
| 28 | - | 24 |
| 31.5 | - | 0 |

MODEL INFORMATION

| Order No. | HP | Volts | Amps | Minimum Circuit Breaker | Phase | Float Switch Style | Cord Length | Discharge Connection | Minimum On Level | Minimum Off Level | Minimum Basin Diameter | Maximum Solids Size | Shipping Weight lbs/kg |
|-----------|----|-------|------|-------------------------|------------------|------------------------|-------------|----------------------|------------------|-------------------|------------------------|---------------------|------------------------|
| EP0411 | .4 | 115 | 12 | 15 | 1 | Plug / No Switch | 10' | 1 1/2" | Manual | Manual | 15" | 3/4" | 20 / 9.1 |
| EP0411A | | | | | | Piggyback / Wide-Angle | 10' | 1 1/2" | 12" | 6" | 15" | | 21 / 9.5 |
| EP0411F | | | | | | Plug / No Switch | 20' | 1 1/2" | Manual | Manual | 15" | | 20 / 9.1 |
| EP0411AC | | | | | | Piggyback / Wide-Angle | 20' | 1 1/2" | 12" | 6" | 15" | | 21 / 9.5 |
| EP0412 | .4 | 230 | 6 | 10 | | Plug / No Switch | 10' | 1 1/2" | Manual | Manual | 15" | | 20 / 9.1 |
| EP0412F | | | | | | Plug / No Switch | 20' | 1 1/2" | Manual | Manual | 15" | | 20 / 9.1 |
| EP0511F | .5 | 115 | 13 | 15 | | Plug / No Switch | 10' | 1 1/2" | Manual | Manual | 15" | | 22 / 10 |
| EP0511AC | | | | | | Piggyback / Wide-Angle | 20' | 1 1/2" | 12" | 6" | 15" | | 23 / 10.4 |
| EP0512F | | | | | Plug / No Switch | 20' | 1 1/2" | Manual | Manual | 15" | 22 / 10 | | |

(CSA listed model numbers end in "C" or "F".)